

P4021 Nov.  
WASSCE 2011  
GENERAL MATHEMATICS/  
MATHEMATICS (CORE) 1  
Objective Test  
1½ hours

**1**

Name: .....

Index Number: .....

**THE WEST AFRICAN EXAMINATIONS COUNCIL**  
**West African Senior School Certificate Examination**

November 2011

GENERAL MATHEMATICS/MATHEMATICS (CORE) 1

1½ hours

OBJECTIVE TEST  
[ 50 marks ]

Do not open this booklet until you are told to do so. While you are waiting, write your name and index number in the spaces provided at the top right-hand corner of this booklet and thereafter, read the following instructions carefully.

- Use HB pencil throughout.
- If you have got a blank answer sheet, complete its top section as follows.
  - In the space marked *Name*, write in capital letters your **surname** followed by your **other names**.
  - In the spaces marked *Examination*, *Year*, *Subject* and *Paper*, write 'WASSCE', '2011 NOV.', 'GENERAL MATHEMATICS/MATHEMATICS (CORE)' and '1', respectively.
  - In the box marked *Index Number*, write your **index number** vertically in the spaces on the left-hand side. There are numbered spaces in line with each digit. **Shade** carefully the space with the same number as each digit.
  - In the box marked *Paper Code*, write the digits **402112** in the spaces on the left-hand side. **Shade** the corresponding numbered spaces in the same way as for your index number.
  - In the box marked *Sex*, shade the space marked **M** if you are **male**, or **F** if you are **female**.
- If you have got a pre-printed answer sheet, check that the details are correctly printed, as described in 2 above. In the boxes marked *Index Number*, *Paper Code* and *Sex*, **reshade** each of the shaded spaces.
- An example is given below. This is for a **male** candidate, whose **name** is **Chukwuma Adekunle CIROMA**, whose **index number** is **5251102068** and who is offering **General Mathematics/Mathematics (Core) 1**.

**THE WEST AFRICAN EXAMINATIONS COUNCIL**

PRINT IN BLOCK LETTERS

Name: CIROMA CHUKWUMA ADEKUNLE Examination: WASSCE Year: 2011 NOV.  
Surname Other Names

Subject: GENERAL MATHEMATICS / MATHEMATICS (CORE) Paper: 1

INDEX NUMBER	
5	0 1 2 3 4 5 6 7 8 9
2	0 1 2 3 4 5 6 7 8 9
5	0 1 2 3 4 5 6 7 8 9
1	0 1 2 3 4 5 6 7 8 9
1	0 1 2 3 4 5 6 7 8 9
0	0 1 2 3 4 5 6 7 8 9
2	0 1 2 3 4 5 6 7 8 9
0	0 1 2 3 4 5 6 7 8 9
6	0 1 2 3 4 5 6 7 8 9
8	0 1 2 3 4 5 6 7 8 9

PAPER CODE	
4	0 1 2 3 4 5 6 7 8 9
0	0 1 2 3 4 5 6 7 8 9
2	0 1 2 3 4 5 6 7 8 9
1	0 1 2 3 4 5 6 7 8 9
1	0 1 2 3 4 5 6 7 8 9
2	0 1 2 3 4 5 6 7 8 9

SEX
Indicate your sex by shading the space marked M (for Male) or F (for Female) in this box: M <input type="checkbox"/> F <input type="checkbox"/>

For Supervisors only.  
If candidate is absent shade this space:

**INSTRUCTIONS TO CANDIDATES**

- Use grade **HB** pencil throughout.
- Answer each question by choosing one letter and shading it like this: [A] [B] [C]
- Erase completely any answers you wish to change.
- Leave extra spaces blank if the answer spaces provided are more than you need.
- Do not make any markings across the heavy black marks at the right-hand edge of your answer sheet.

Answer **all** the questions.

Mathematical tables may be used in any question.

The use of non-programmable, silent and cordless calculator is allowed.

**Each** question is followed by **four** options lettered A to D. Find out the correct option for **each** question and shade **in pencil** on your answer sheet the answer space which bears the same letter as the option you have chosen. Give only **one** answer to **each** question. An example is given below.

The ages, in years, of **four** boys are 10, 12, 14, and 18. What is the average age of the boys?

- A. 12 years
- B.  $12\frac{1}{2}$  years
- C. 13 years
- D.  $13\frac{1}{2}$  years

The correct answer is  $13\frac{1}{2}$  years, which is lettered D, and therefore answer space D would be shaded.

[ A ]

[ B ]

[ C ]

[ D ]

Think carefully before you shade the answer spaces; erase completely any answer you wish to change.

Do all rough work on this question paper.

Now, answer the following questions.

1. A money lender collects \$200 simple interest on a capital after 2 years at 5%. Calculate the capital invested.
  - A. \$1,000.00
  - B. \$2,000.00
  - C. \$3,000.00
  - D. \$4,000.00
  
2. Simplify:  $\log_{10}2 \cdot 25 + 4\log_{10}2 - 2\log_{10}0.6$ .
  - A. 1
  - B. 2
  - C. 3
  - D. 4

3. Simplify:  $5\sqrt{12} - 4\sqrt{75} + 3\sqrt{48}$ .
- A.  $3\sqrt{3}$   
B.  $2\sqrt{3}$   
C.  $-2\sqrt{3}$   
D.  $-3\sqrt{3}$
4. A book seller gives 5% discount to a customer who pays cash. What is the marked price of a book for which the customer pays ₦475.00?
- A. ₦300.00  
B. ₦400.00  
C. ₦500.00  
D. ₦600.00
5. If  $y$  varies inversely as the cube root of  $x$  and  $y = 4$  when  $x = 27$ , find  $y$  when  $x = 8$ .
- A. 6  
B. 4  
C. 3  
D. 2
6. The  $n$ th term of a sequence is  $2^{2n} \left(-\frac{1}{2}\right)^n$ . Find the third term.
- A. -512  
B. -64  
C. -32  
D. -8
7. If  $y\%$  of a number  $n$  equals  $k$ , what is  $3\%$  of  $n$ ?
- A.  $\frac{k}{3y}$   
B.  $\frac{3k}{y}$   
C.  $\frac{k}{300y}$   
D.  $\frac{3k}{100y}$

14. If  $x + 2y = 7$  and  $4x + 11y = 34$ , by how much is  $3y$  less than 10?

- A. 3
- B. 4
- C. 5
- D. 7

15. Solve the equation:  $7x^2 - 3x - 10 = 0$ .

- A.  $-1, \frac{10}{7}$
- B.  $1, -\frac{10}{7}$
- C.  $-1, -\frac{10}{7}$
- D.  $1, \frac{10}{7}$

16.

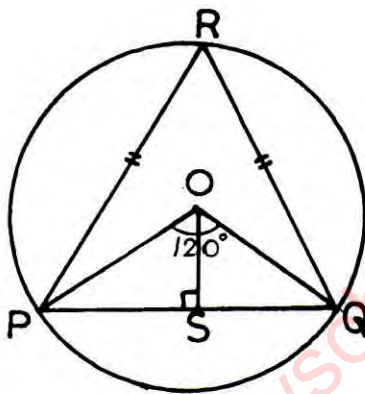

In the diagram,  $P, Q$  and  $R$  are points on a circle with centre  $O$ . The chord  $|PQ| = 10\sqrt{3}$  cm,  $\angle OSQ = 90^\circ$  and  $\angle POQ = 120^\circ$ . Find  $|RS|$ .

- A. 15 cm
- B.  $15\sqrt{3}$  cm
- C. 25 cm
- D.  $25\sqrt{3}$  cm

17. A rectangular tank 82 cm long, 37 cm wide and 75 cm deep has the same volume as a cylindrical tank. If the radius of the cylindrical tank is 30 cm, calculate its height.

[ Take  $\pi = 3.14$  ]

- A. 83.00 cm
- B. 80.52 cm
- C. 52.80 cm
- D. 50.80 cm

18. A chord  $PR$  of a circle, centre  $O$ , is  $20\text{ cm}$  long. If  $\widehat{POR} = 120^\circ$ , calculate the radius of the circle.
- A.  $16.0\text{ cm}$
  - B.  $13.0\text{ cm}$
  - C.  $11.5\text{ cm}$
  - D.  $11.2\text{ cm}$

19.  $PQ$  is the diameter of a circle  $PQR$ .  $|PR| = 9\text{ cm}$  and  $|RQ| = 12\text{ cm}$ . Calculate the area of the circle.

[ Take  $\pi = \frac{22}{7}$  ]

- A.  $88.4\text{ cm}^2$
  - B.  $144.0\text{ cm}^2$
  - C.  $176.8\text{ cm}^2$
  - D.  $225.0\text{ cm}^2$
20. In an octagon, three of the interior angles are  $x^\circ$  each. Each of the remaining five interior angles is  $(16 + x)^\circ$ . Find the value of  $x$ .
- A.  $102^\circ$
  - B.  $105^\circ$
  - C.  $120^\circ$
  - D.  $125^\circ$

21.

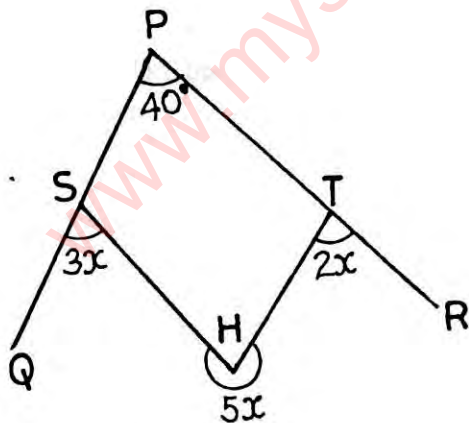

In the diagram,  $PSQ$  and  $PTR$  are straight lines, reflex  $\angle SHT = 5x$ ,  $\angle HTR = 2x$  and  $\angle QSH = 3x$ .

Find the value of  $x$ .

- A.  $32^\circ$
- B.  $40^\circ$
- C.  $68^\circ$
- D.  $70^\circ$

22.

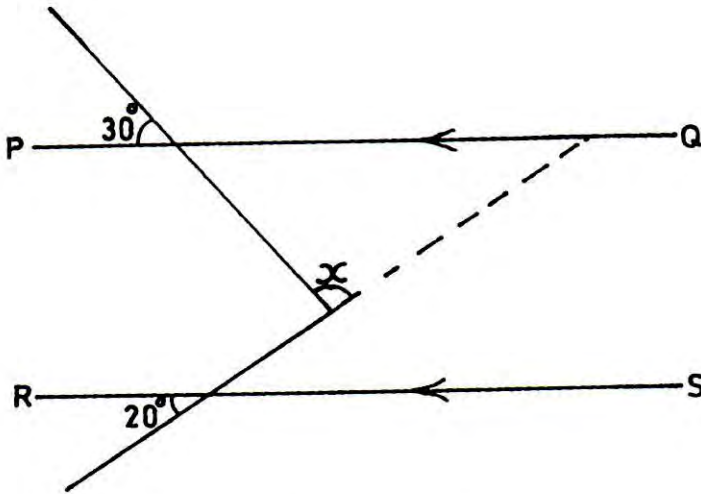

In the figure,  $\overline{PQ} \parallel \overline{RS}$ . Find the value of the angle marked  $x$ .

- A.  $90^\circ$
- B.  $120^\circ$
- C.  $125^\circ$
- D.  $130^\circ$

23.

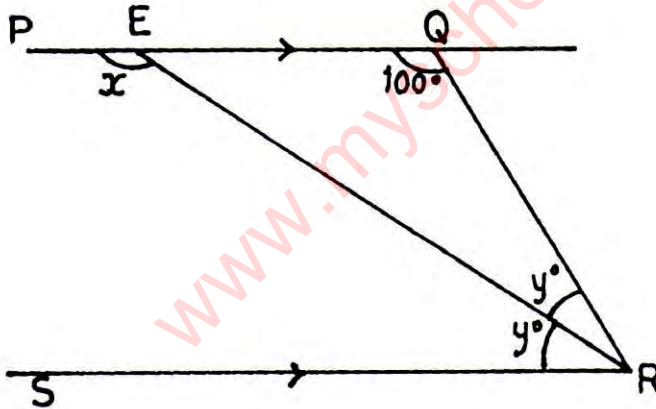

In the diagram,  $\overline{PQ}$  is parallel to  $\overline{SR}$ ,  $\angle EQR = 100^\circ$  and  $\overline{ER}$  bisects  $\angle QRS$ . Find the value of  $x$ .

- A.  $120^\circ$
- B.  $130^\circ$
- C.  $140^\circ$
- D.  $150^\circ$

24.

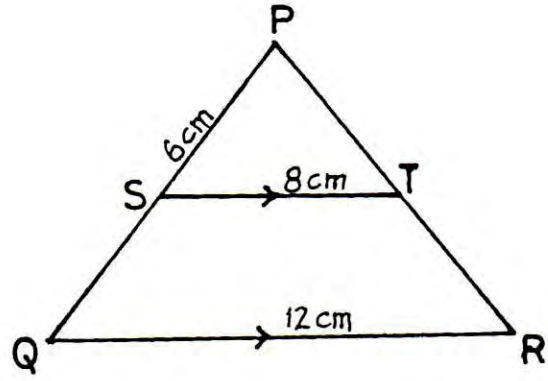

In the diagram,  $\overline{ST} \parallel \overline{QR}$ ,  $|PS| = 6 \text{ cm}$ ,  $|ST| = 8 \text{ cm}$  and  $|QR| = 12 \text{ cm}$ . Calculate  $|SQ|$ .

- A. 6 cm
- B. 5 cm
- C. 4 cm
- D. 3 cm

25.

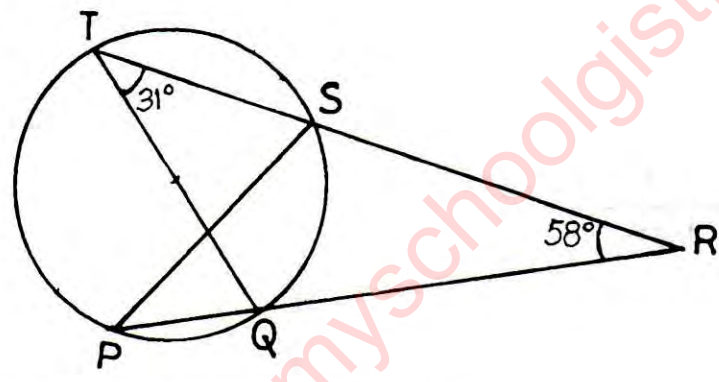

Find the value of  $\angle TSP$  in the diagram.

- A.  $91^\circ$
- B.  $89^\circ$
- C.  $71^\circ$
- D.  $69^\circ$

26. The bearing of  $P$  from  $Q$  is  $N5^\circ W$ . Find the true bearing of  $Q$  from  $P$ .

- A.  $100^\circ$
- B.  $175^\circ$
- C.  $180^\circ$
- D.  $185^\circ$

27. If  $\cos p = 0.8$ , evaluate  $20 \tan p \sin p$ .
- 6
  - 9
  - 12
  - 18
28. A ladder 5 m long leans against a vertical wall. The foot of the ladder is 3 m from the wall on the same horizontal ground. Calculate, correct to the nearest degree, the angle which the ladder makes with the wall.
- $35^\circ$
  - $37^\circ$
  - $38^\circ$
  - $39^\circ$
29. What is the probability that an event E will surely occur?
- $\Pr(E) = 1$
  - $\Pr(E) \neq 0$
  - $\Pr(E) < 1$
  - $\Pr(E) > 0$

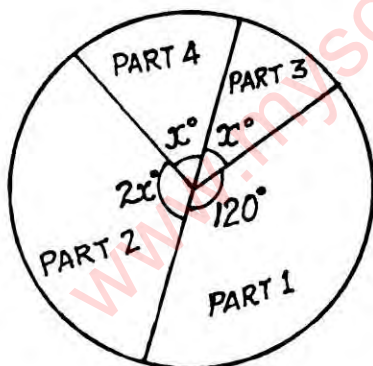

The pie chart represents the distribution of 900 undergraduates in a university. Use the information to answer questions 30 and 31.

30. Calculate the value of  $x$ .
- $36^\circ$
  - $60^\circ$
  - $72^\circ$
  - $108^\circ$



24.

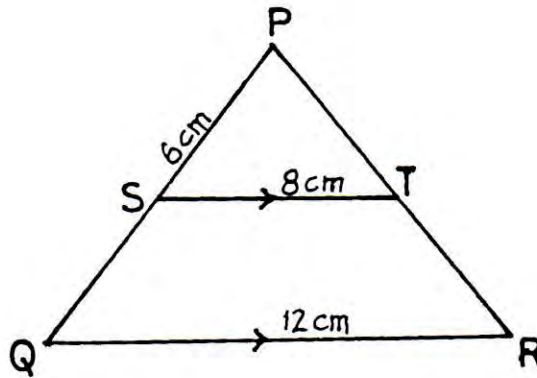

In the diagram,  $\overline{ST} \parallel \overline{QR}$ ,  $|PS| = 6 \text{ cm}$ ,  $|ST| = 8 \text{ cm}$  and  $|QR| = 12 \text{ cm}$ . Calculate  $|SQ|$ .

- A. 6 cm
- B. 5 cm
- C. 4 cm
- D. 3 cm

25.

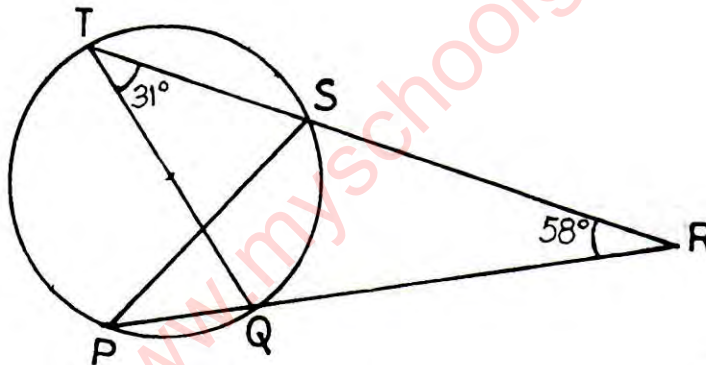

Find the value of  $\angle TSP$  in the diagram.

- A.  $91^\circ$
- B.  $89^\circ$
- C.  $71^\circ$
- D.  $69^\circ$

26. The bearing of  $P$  from  $Q$  is  $N5^\circ W$ . Find the true bearing of  $Q$  from  $P$ .

- A.  $100^\circ$
- B.  $175^\circ$
- C.  $180^\circ$
- D.  $185^\circ$

31. How many undergraduates are in Part 3?

- A. 100
- B. 120
- C. 150
- D. 180

32. If the mean of 15,  $x$ , 18 and 13 is 19, find the median.

- A. 15.0
- B. 15.5
- C. 16.5
- D. 18.0

33. Aku, Kay and Badu share an amount in the ratio 2:5:9 respectively. If Badu receives GH¢48.00 more than Kay, find the amount shared.

- A. GH¢92.00
- B. GH¢126.67
- C. GH¢153.60
- D. GH¢192.00

34. Simplify:  $6\frac{1}{3} - 2\frac{3}{4} + 1\frac{1}{6}$ .

- A.  $4\frac{3}{4}$
- B.  $4\frac{1}{5}$
- C.  $2\frac{1}{4}$
- D.  $\frac{11}{30}$

35. Simplify:  $\left[\frac{3}{x} - \frac{15}{2y}\right] \div \frac{6}{xy}$ .

- A.  $\frac{2y - 5x}{4}$
- B.  $\frac{3(2y - 5x)}{2x^2y^2}$
- C.  $\frac{5x - 2y}{4}$
- D.  $\frac{x^2y^2}{18y - 45x}$

36.

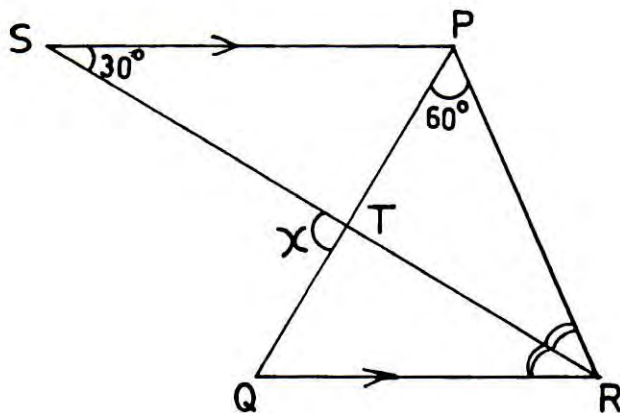

In the figure,  $PS \parallel QR$ .  $SR$  bisects angle  $PRQ$ . If  $\angle PST = 30^\circ$  and  $\angle RPQ = 60^\circ$ , calculate angle  $x$ .

- A.  $105^\circ$
- B.  $100^\circ$
- C.  $95^\circ$
- D.  $90^\circ$

37.

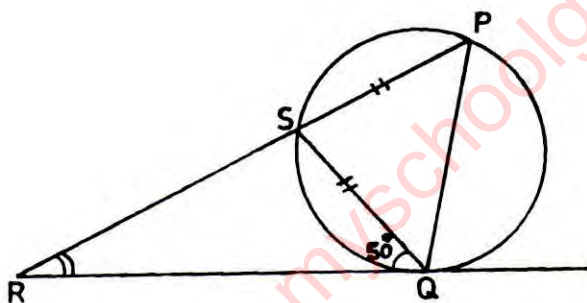

In the diagram,  $\overline{RQ}$  is a tangent to the circle,  $|PS| = |SQ|$  and  $\angle SQR = 50^\circ$ . Calculate  $\angle SRQ$ .

- A.  $30^\circ$
- B.  $35^\circ$
- C.  $40^\circ$
- D.  $45^\circ$

38. Two students are selected at random from 5 boys and 4 girls. Find the probability that both are boys.

- A.  $\frac{5}{18}$
- B.  $\frac{2}{9}$
- C.  $\frac{5}{9}$
- D.  $\frac{20}{81}$

36.

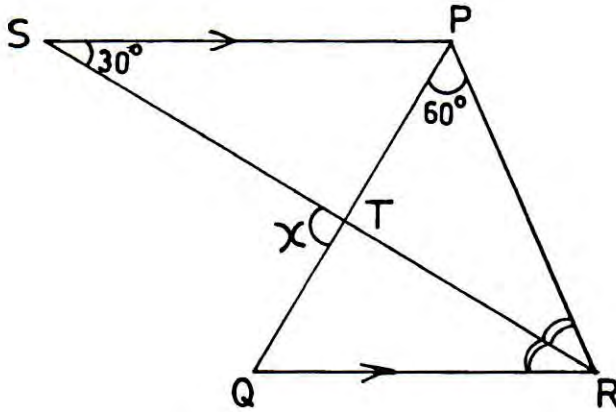

In the figure,  $PS \parallel QR$ .  $SR$  bisects angle  $PRQ$ . If  $\angle PST = 30^\circ$  and  $\angle RPQ = 60^\circ$ , calculate angle  $x$ .

- A.  $105^\circ$
- B.  $100^\circ$
- C.  $95^\circ$
- D.  $90^\circ$

37.

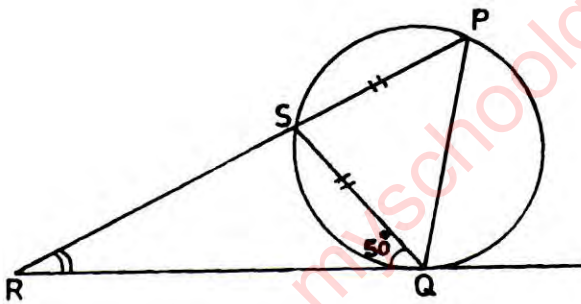

In the diagram,  $\overline{RQ}$  is a tangent to the circle,  $|PS| = |SQ|$  and  $\angle SQR = 50^\circ$ . Calculate  $\angle SRQ$ .

- A.  $30^\circ$
- B.  $35^\circ$
- C.  $40^\circ$
- D.  $45^\circ$

38. Two students are selected at random from 5 boys and 4 girls. Find the probability that both are boys.

- A.  $\frac{5}{18}$
- B.  $\frac{2}{9}$
- C.  $\frac{5}{9}$
- D.  $\frac{20}{81}$

39. Calculate the perimeter of a quadrant of a circle, radius  $10.5 \text{ cm}$ .

[ Take  $\pi = \frac{22}{7}$  ]

- A.  $37.5 \text{ cm}$
- B.  $36.0 \text{ cm}$
- C.  $32.5 \text{ cm}$
- D.  $27.0 \text{ cm}$

40.  $P$  and  $Q$  are two intersecting subsets of a universal set  $E$ . If  $n(P) = 25$ ,  $n(Q) = 20$ ,  $n(P \cup Q)' = 5$  and  $n(E) = 40$ , find  $n(P \cap Q)$ .

- A. 5
- B. 10
- C. 15
- D. 20

41. The perpendicular height of a pyramid is  $12 \text{ m}$ . If its base is a square of side  $5 \text{ m}$ , calculate its volume.

- A.  $200 \text{ m}^3$
- B.  $100 \text{ m}^3$
- C.  $80 \text{ m}^3$
- D.  $60 \text{ m}^3$

42.

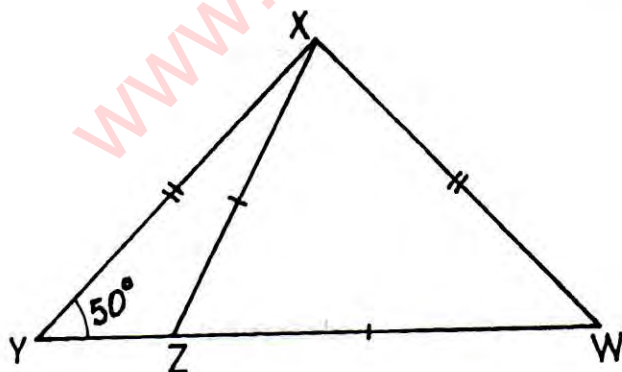

In the diagram,  $WXY$  is a triangle.  $|XY| = |XW|$ ,  $|XZ| = |WZ|$  and  $\angle XYZ = 50^\circ$ . Find  $\angle XZW$ .

- A.  $55^\circ$
- B.  $65^\circ$
- C.  $70^\circ$
- D.  $80^\circ$

43. Express the sum of  $10^{-2}$  and  $10^{-3}$  in standard form.
- A.  $1.0 \times 10^{-6}$
  - B.  $1.0 \times 10^{-4}$
  - C.  $1.1 \times 10^{-3}$
  - D.  $1.1 \times 10^{-2}$
44. Given that  $r = \frac{xy}{2}$  and  $x = \frac{v}{w}$ , express  $r$  in terms of  $y$ ,  $v$  and  $w$ .
- A.  $\frac{2vw}{y}$
  - B.  $\frac{vw}{2y}$
  - C.  $\frac{vwy}{2}$
  - D.  $\frac{vy}{2w}$
45. Calculate the length of the diagonal of a square whose area is  $p \text{ cm}^2$ .
- A.  $\sqrt{p}$
  - B.  $2\sqrt{p}$
  - C.  $p\sqrt{2}$
  - D.  $\sqrt{2p}$
46. If  $2p^2 = \frac{1}{2}$  and  $pq = 2$ , find the values of  $q$ .
- A.  $-4, 4$
  - B.  $-2, 2$
  - C.  $2, 2$
  - D.  $4, 4$

47.

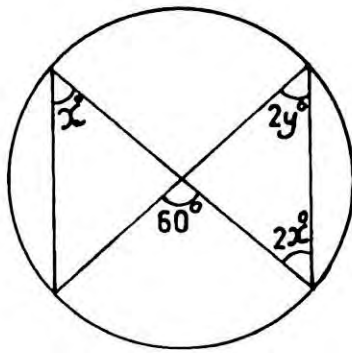

Find the value of  $y$  in the diagram.

- A. 10
- B. 15
- C. 20
- D. 30

48. Convert  $2201_{\text{four}}$  to a base ten numeral.

- A. 128
- B. 137
- C. 161
- D. 165

49.

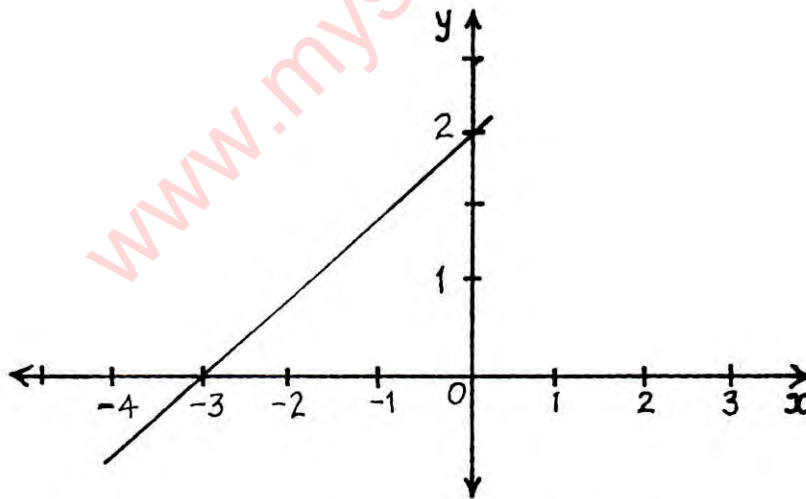

Which of the following equations satisfies the linear graph above?

- A.  $3y = 2x - 6$
- B.  $2y = -3x + 6$
- C.  $3y = 2x + 6$
- D.  $2y = 3x - 6$

50.

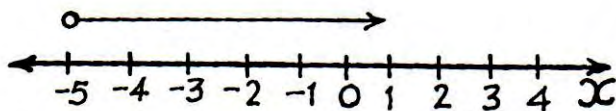

Which of the following inequalities is represented by the number line?

- A.  $x \geq -5$
- B.  $x > -5$
- C.  $x < -5$
- D.  $x \leq -5$

[www.myschoolgist.com](http://www.myschoolgist.com)